

HYPERBOLIC FLAT-FIELD ASTROGRAPH

E-180ED

INSTRUCTION MANUAL

TAKAHASHI

Thank you for purchasing the TAKAHASHI Epsilon-180ED (E-180ED) hyperbolic astrograph. The E-180ED employs a new 2-element corrector that uses an ED element, which provides much better correction than a Schmidt camera for aberrations. The E-180ED has been designed as an astrograph for imaging with digital SLR's, CCD cameras and film cameras. Please read the instruction manual to familiarize yourself with the functions of the telescope and its features and their functions.

WARNING

DO NOT UNDER ANY CIRCUMSTANCES POINT THE TELESCOPE AT THE SUN NOR TRY TO OBSERVE THE SUN. THIS WILL RESULT IN INSTANT BLINDNESS AND SEVERE BURNS.

THIS TELESCOPE SHOULD NOT BE TAKEN OUT DURING THE DAY. THE SUN WILL HEAT THE INSIDE OF THE TUBE AND MAKE THE COOL DOWN TIME VERY LONG.

KEEP THIS TELESCOPE OUT OF THE REACH OF CHILDREN DURING THE DAY. THIS TELESCOPE IS DESIGNED TO BE USED EXCLUSIVELY AT NIGHT.



CAUTION

- When placing the E-180ED into the tube holder, make certain that the holder is level and both axes of the mount locked to insure that the telescope will not be tilted and fall to the ground.
- If the E-180ED is placed on a surface such as table, make certain that it is flat to prevent the telescope from rolling off on the ground and breaking.
- Keep the telescope out of any direct sun light.
- Keep small children away from small objects such as oculars to prevent from swallowing something that can harm them.
- Keep the shipping carton in a safe, dry place and away from any flame. The carton can be used as a temporary travel case.

CONTENTS

Warning & Caution	2
Specifications	3
Tube Assembly Layout	4
What is the E-180ED?	5
Attaching Finder Tube Holder	6
Focusing System	8
Finder Alignment	11
Observation	13
Photographic Accessories	16
Optical Alignment	17
Care & Maintenance	25
System Chart	26

SPECIFICATIONS

Optical System	Hyperboloidal Catadioptric
Effective Aperture	180mm
Effective Focal Length	500mm
Effective Focal Ratio	1:2.8
Secondary Mirror Diameter	80mm
Corrector Lens	ED 2-element
Image Circle	ϕ 44mm
Photographic Field	5.0 degrees
Metal Back	56mm
Diameter of Main Tube	232mm
Length of Main Tube Ass'y	570mm
Weight of Main Tube Ass'y	10.7kg (23.6lbs) w/7x50 finder
Finder Scope	7x50 6.3"
Focusing System	Rack & Pinion

Tube Assembly Layout

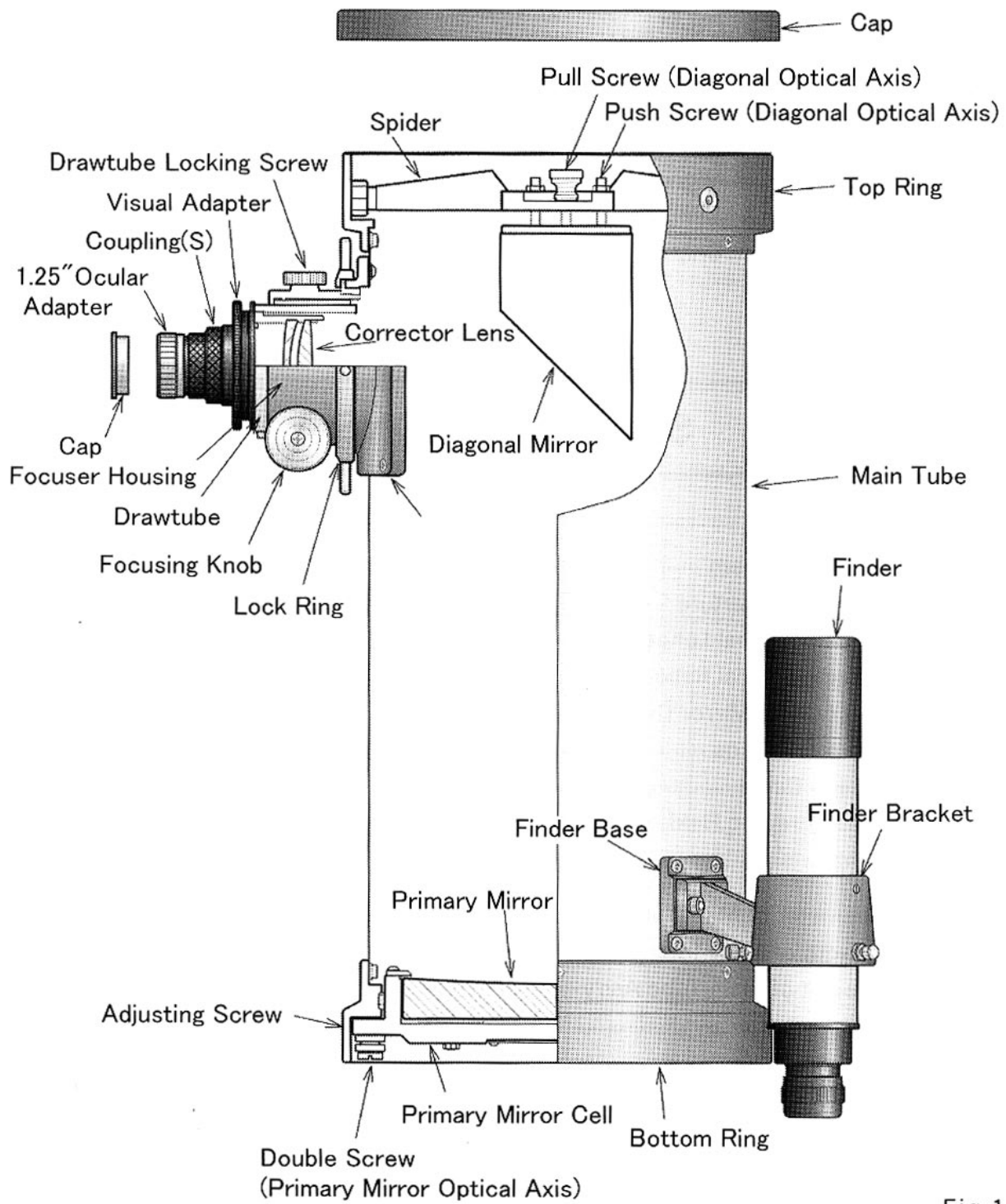

Fig. 1

What is the E-180ED?

■ Optical System

A Newtonian reflector can not produce the same flat field as the Pezval four element refractors for astrophotography. A concave mirror used with a convex lens can produce a flat field also. The lens referred to here is a doublet corrector used with a hyperbolic primary can also produce a flat field corrected for spherical aberration and coma. This is the E-180ED.

■ E-180ED Built for the Age of Digital Camera

The E-180ED is an advanced design of the Epsilons hyperbolic astrograph design. The new design doublet corrector employs an ED element to correct aberrations as well as a Schmidt camera. Compared to the older Epsilons, the aberrations from the ultra violet to infra red are 1/2 those of the original design Epsilon.

This f/2.8 system will produce 10 micron star across the 5 field. The small distortions of the original design have been improved by 1/3rd.

The oversized diagonal reduces a larger illuminated circle. The E-180ED is the perfect fast wide field astrograph for digital SLR's and CCD cameras.

■ Takahashi Mirror Making Technology

Takahashi has been producing hyperbolic mirrors for more than 20 years and they have improved their production procedure to produce the highest quality hyperbolic primaries.

■ Diagonal Offset

In order to achieve the maximum illumination the secondary must be offset from the center of the optical axis to produce the best possible illumination for the image. As the speed of the optical system increases, so does the offset. The oversized secondary has been offset to produce the maximum illumination for the image.

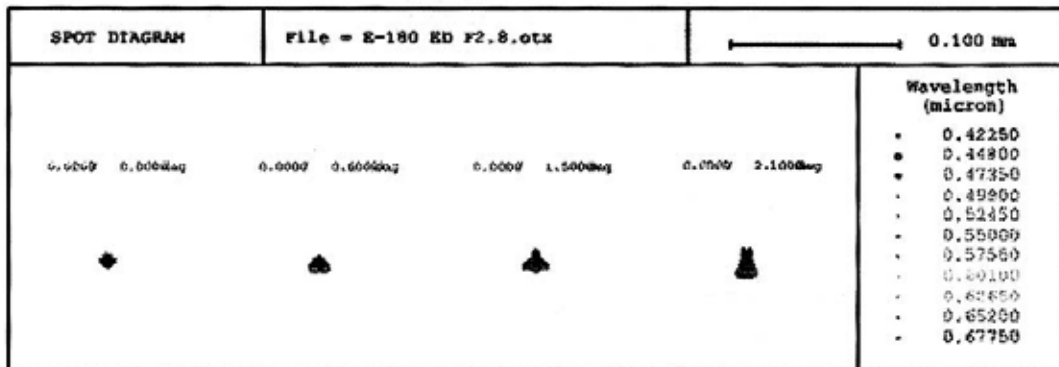

Fig.2

Attaching The Finder And Tube Assembly

The E-180ED is shipped with the finder in a separate box to prevent damage during shipping. Use the following instructions to assemble the finder and bracket and tube holder.

■ Attaching The Finder

Attach the finder bracket using the 5mm x 1.5 provided as illustrated in the Fig.3. Do not screw in the bolts without the finder bracket since they will bottom out in the end of the tapped hole.

Before inserting the finder into the finder bracket, wrap the area that the finder bracket screws will make contact with the body of the finder with three layers of clear tape to prevent scratches from being made on the place where the screws make contact with the tube.

Then, screw out the rear set until nylon tip makes contact with the bracket and the front screws until they no longer protrude inside the finder bracket. Insert the finder for an infinity target during the day and lock the rear screws with the lock nuts and make certain that the front set of screws are in firm contact with the body of the finder.

Note that the chrome screw near the eyepiece is removed to insert the optional reticle illuminator.

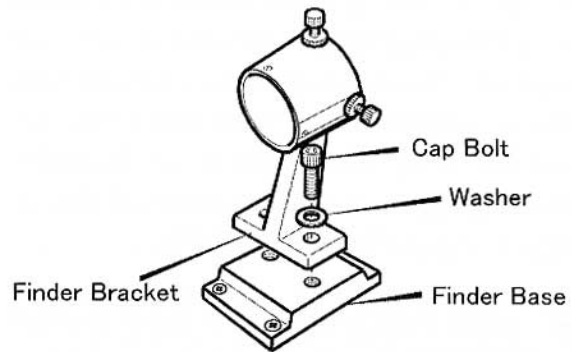

Fig. 3

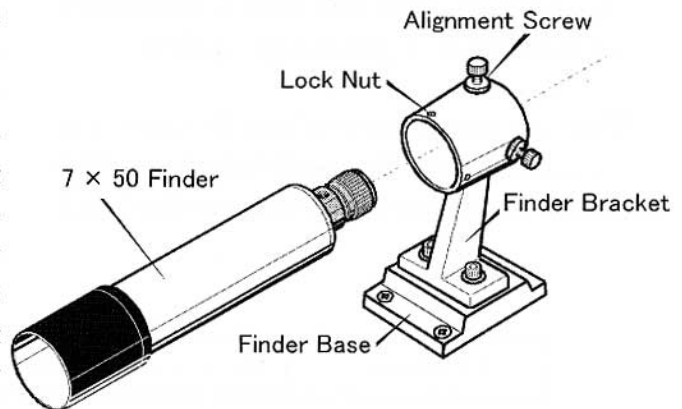

Fig. 4

⚠ CAUTION

Never use the finder and bracket as a handle to lift the E-180ED. This will cause the finder to lose its alignment and could cause damage to the bracket holding the finder to the tube.

■ Attaching the Tube Holder

Attach the tube holder to the M-plate (S) or (M) with the bolts provided and do not tighten them too tightly, but center the holder in the bracket. Turn the Dec. axis until the base of the plate is parallel to the ground and lock the axis.

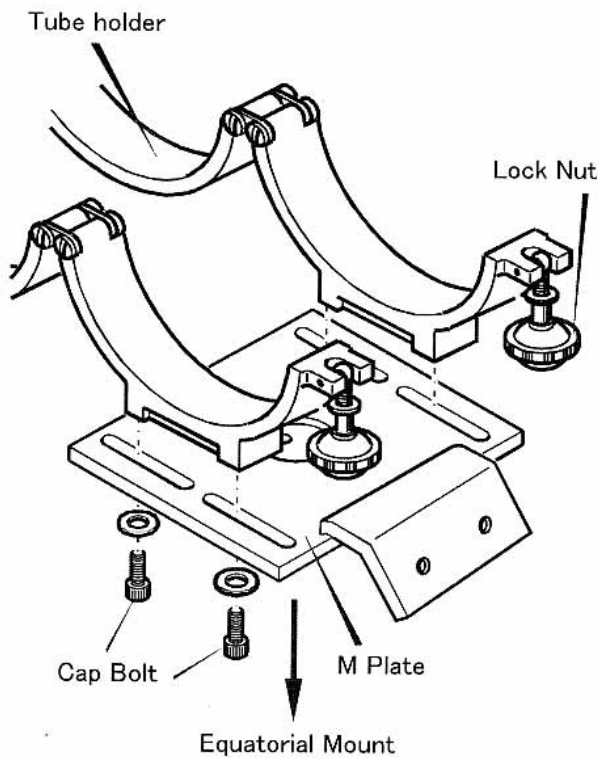

Fig.5

■ Balancing

Place the E-180ED into the holder and tighten the clamps to the point where the OTA is held, but still can be slide forwards or backwards for balance. Then, unlock the Dec. clamp but hold the OTA with one hand for safety. Let go then to balance the tube. If any equipment will be used, attach the camera before balancing. It is best to have the focuser pointing skyward when this procedure is done.

Then, unclamp the R.A. but hold on to the OTA. Move the counter weights on the shaft until the instrument is balanced in any position it is moved.

Further, when imaging begins it is a good idea to balance the instrument and camera in the arc in which it will be used to image. This insures superior tracking.

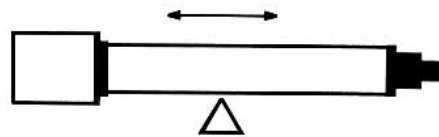

Fig.6

Focusing System

* Visual Adapter Assembly

■ Focuser & Camera Angle Adjuster (CAA)

The E-180ED is supplied with a rack and pinion focuser with a built-in camera angle adjuster (CAA) which allows the camera to be rotated 360° without loss of focus. This allows the imager to perfectly frame the image. The large ring at the base of the focuser is the rotator clamp.

Turn the ring counter-clockwise to loosen the CAA and a clockwise turn to tighten the camera.

There is also a focus lock knob to insure that focus is maintained during an imaging session. Be certain to loosen the focus lock when focusing is done.

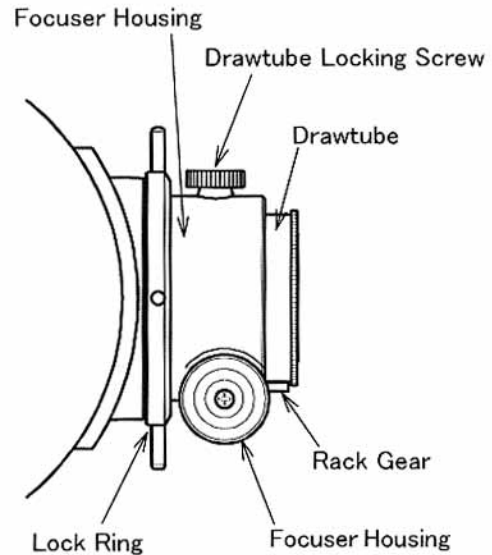

Fig.7

■ Camera Angle Adjuster (CAA)

As mentioned previously the E-180ED is provided with a CAA to allow 360° rotation of the camera, digital SLR or CCD cameras. The spokes on the lock ring allows the user to easily lock and unlock the CAA.

An MEF 10 to 1 fine focuser can be attached to the focuser, if needed.

■ Corrector

The 2-element ED corrector is placed inside of the focuser draw tube. This corrector flattens and corrects the photographic field. It is removed when collimating the E-180 and must be re-inserted when imaging begins.

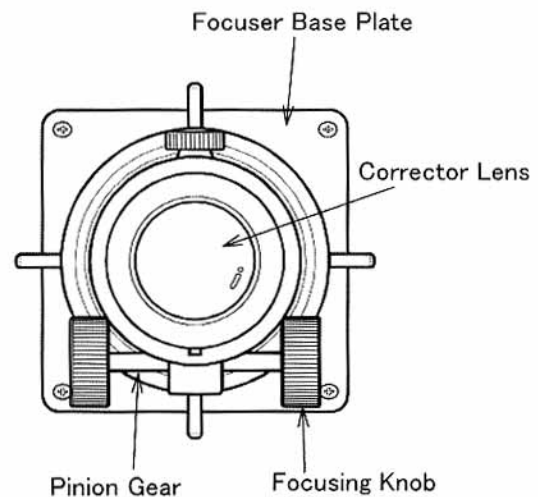

Fig.8

■ Focusing

After inserting the ocular or attaching the camera, it is best to achieve the best possible focus. Since the MEF 10 to 1 fine focuser or aftermarket electric focusers can be used with the E-180ED, very precise focus can be achieved.

● Focusing System

The E-180ED uses a rack-and-pinion focusing system. This system permits rapid focusing. By turning the arrowed direction, the focuser will move out and by turning the knob reversely, the focuser will move in. Refer to the Fig.9.

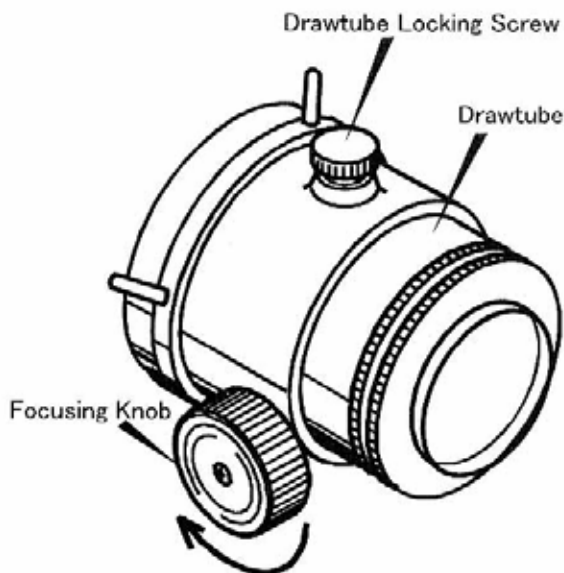

Turn the knob this way.
Then, the focuser move out.

Fig.9

● Focus Clamp

The focus clamp is provided to lock the draw tube. Then, the image is precisely focused. When a camera is precisely focused, then the focus clamp will lock the focus. When the focus is changed, loosen the focus clamp until focus is achieved again for the next image.

■ MEF-1 (Micro Edge Focuser)

This optionally available 10 to 1 fine focuser can be attached in a few minutes. It features 10 to 1 micro focusing with adjustable drag. It can be ordered with the E-180ED. Refer to the Fig.10.

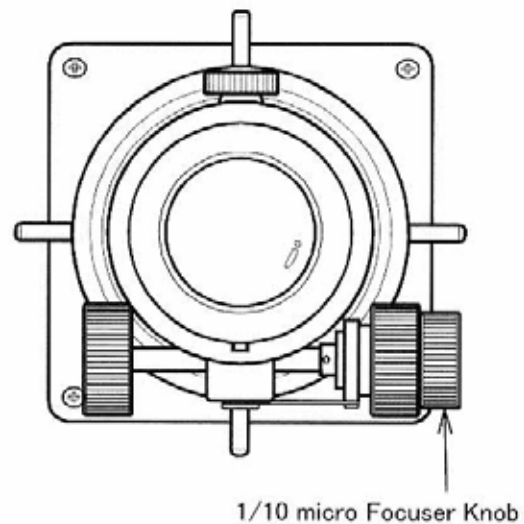

Fig.10

■ Visual Use

Since the E-180 is f/2.8, if it will be used visually, remember that the large secondary precludes the use of any ocular longer than the Takahashi LE-12.5mm or shorter. The oversized secondary which illuminates the field limits the focal length of the ocular that can be used to 12.5mm.

The E-180 is supplied with the standard 1 1/4" compression ring adapter. Insert the ocular into the holder and tighten the compression ring.

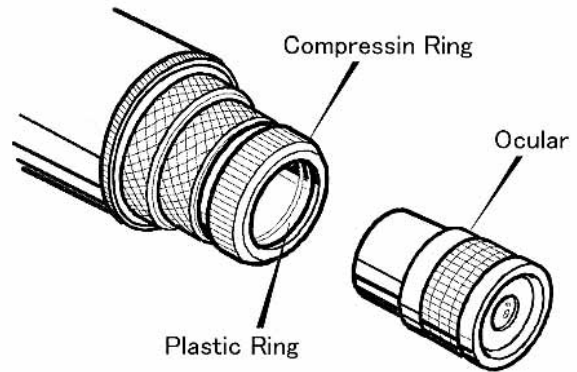

Fig.11

■ Oculars

The following oculars are available from Takahashi. Use them in the best way.

● LE Oculars

A wide selection of wide field oculars are available from 5mm to 30mm.

● Hi LE Oculars

Hi LE-2.8mm and HI LE-3.6mm are available.

Finder Alignment

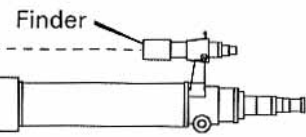

Before the finder is placed in the finder holder, use plastic clear tape and tape the finder with two layers to prevent the tube from being scratched by the front finder set screws.

A finder is a useful tool. It permits the precise centering of an object in the field of view. The 6.3° field of view allows the easy centering of an object to be viewed or photographed.

The Takahashi finder uses an interrupted crosshair which is designed to allow the easy centering of an object to be photographed or observed. The wide field of the finder makes the finding of an object easier, therefore, it is important that the finder and the telescope be in alignment. The following procedure can be used to align the finder.

◆ Alignment Procedure

1. Place a low power eyepiece in the telescope and center a bright star in a convenient part of the sky. Do not forget to engage the motor drive to keep the star centered. If this procedure is done in daylight, use an object that is at least one mile away. Loosen the lock nuts on the finder bracket and slightly move the star to the center of the field using the adjusting alignment screws.
2. Then use a higher magnification eyepiece and repeat the procedure by centering the object in the field of view of the telescope and then the finder. Continue this process until the highest possible magnification has been used.

◆ Adjusting Screw Procedure

1. Turn all the lock nuts until they reach the head of the alignment screws.

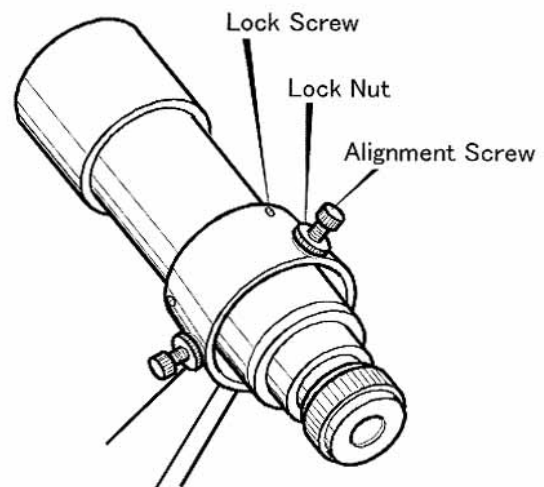

Fig. 12

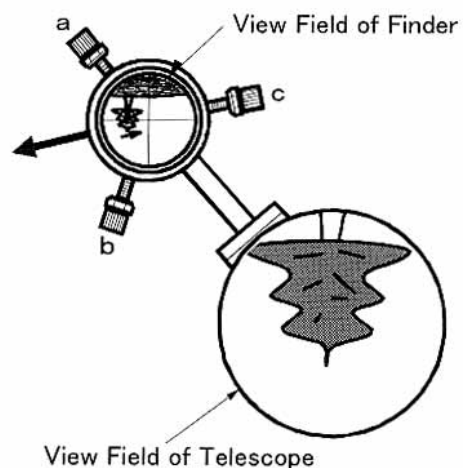

Fig. 13

2. In order to move the crosshair in the direction of the arrow, first loosen screw (a) and tighten (push) the finder with screw (c). This procedure will move the crosshair in the desired direction. The top of the finder will move in the opposite direction and the object will move in the direction of the smaller arrow. Refer to Fig.12,13.
3. In a similar fashion the direction of the movement of the finder is made by adjusting the three screws.

Learn the relationship between the movement of the three adjusting screws. If the finder cannot be moved in the desired direction, loosen the locking nuts.

◆ Reticle Illuminator [Optional]

The 7X50 finder has provision for an optional reticle illuminator. If an illuminator will be installed, remove the cap screw at the end of the finder and install the reticle illuminator. The illuminator makes the centering of dim objects easier.

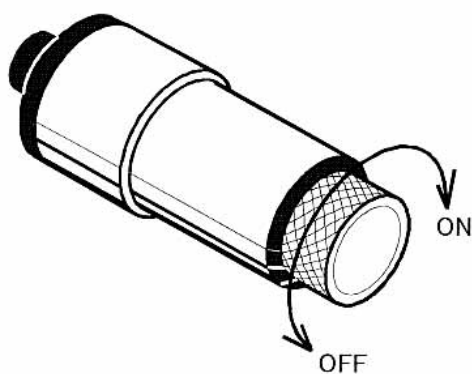

Fig. 14

In order to turn the illuminator on, turn the knob clockwise. The knob will click when the illuminator turns on. As the knob is turned, the reticle will brighten. Adjust the knob to the desired brightness. Turn the knob counter-clockwise past the click to turn the illuminator off. Refer to Fig.14.

◆ Replacing The Battery

Before changing the batteries in the illuminator, please be certain to turn it off. Unscrew the battery holder as shown in Fig.14. Remove the old batteries and insert new one after they have been wiped with a clean dry cloth. Check the polarity of the batteries before inserting them into the holder. Use two silver [V76-PK] or equivalent batteries.

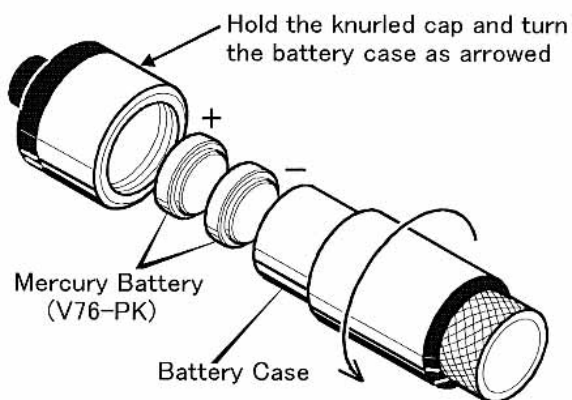

Fig. 15

Observation

■ Cool Down

The E-180ED uses an oversized primary of 190mm which requires a cool down period for the temperature of the primary mirror to equalize with the outdoor temperature. This is especially true in the colder winter.

It is advisable to take the instrument out about an hour before it intended use to insure temperature equalization.

■ Visual Observation

◆ Determining Magnification

The E-180ED has been designed as a flat-field astrograph. Due to the oversized secondary which provides illumination for imaging. As a result it is advisable to use ocular 12.5mm or shorter in focal length. This is perfect for high contrast deep space viewing. Using a longer focal length will show the shadow of the secondary.

The effective magnification is determined by dividing the focal length of the E-180ED 500mm by the focal length of the ocular, 12.5mm in this case producing a magnification of 19.69X, this is a great magnification for wide field viewing.

■ Astro Imaging

Critical focus is necessary to produce the flat-field pin point star that the E-180ED is designed. This focus should be rechecked with each image made.

◆ Prime Focus Photography

The E-180ED is designed to be used at its native focal length of 500mm. Due to its speed of f/2.8, the depth of field is very small and requires precise and excellent focus. It is necessary to use a heavy duty accurate mount to the tracking accuracy to match the very small 10 micron stars.

◆ Prime Focus Photography

The corrector assembly uses a Takahashi wide mount T-ring. Therefore, an adapter that has these wide mount T-threads and the appropriate adapter on the other end to attach it to a digital SLR. These are available as well as adapters for CCD and film cameras.

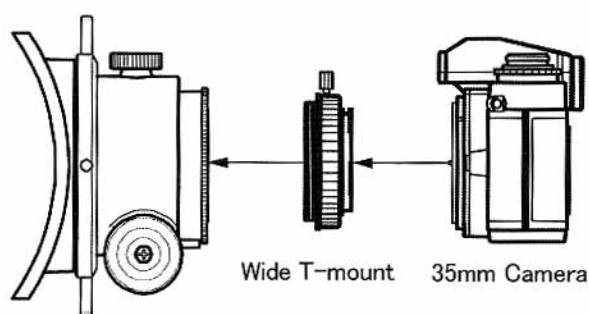

Fig. 16

◆ Focusing

Focusing with the FM-60 focusing microscope and ground glass is shown in Fig.15. Set the ground glass in place with the mat side facing the objective of the TOA. Then focus and check for pinpoint focus over the field of view.

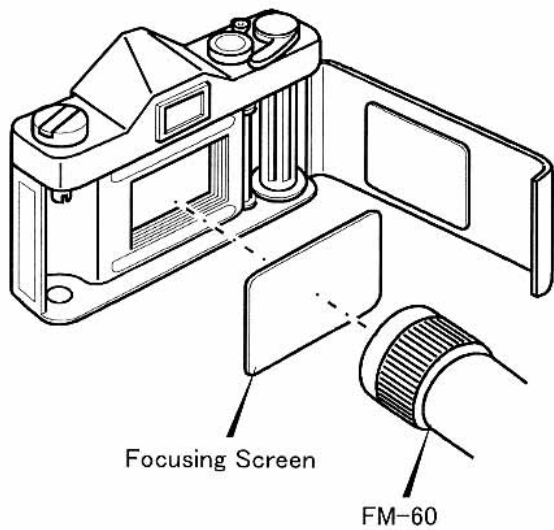

Fig.17

◆ Filters

Filters can be attached to the E-180ED optical train. A 48mm filter can be attached to the wide mount T-adapter for digital and film SLR's and a 52mm filter to the corrector.

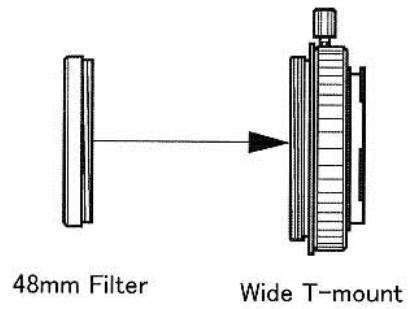

Fig.18

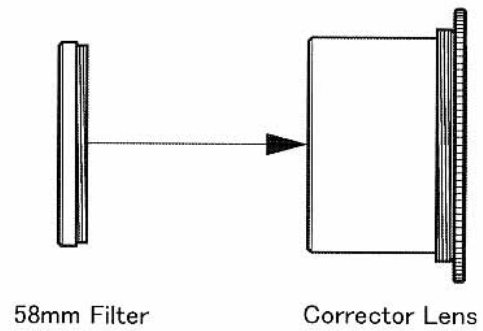

Fig.19

If this is done, it is possible that these filters could cause ghosting and require a different focus point due to their thickness.

◆ Astrophotography Considerations

● Best Focus

Since the stars in the field of the E-180ED are only 10 microns, very precise focus is needed to keep the stars pinpoint on the image. A manual micro, electric or computer controlled focuser are best to use with digital SLR's and CCD camera.

If a 35mm camera is used then best focus can be achieved by using the Takahashi FM-60 focusing microscope and a vacuum back 35mm camera to keep the film flat.

● Test Images

Before taking the E-180ED to a remote site, it is best to try some short (2 to 5 minutes) test shots to test focusing and guiding techniques.

● Reminders

1. Make certain the Camera Angle Adjuster lock ring has been tightened to prevent the camera from moving while an image is taken.
2. Follow the system chart when using a digital or film SLR and check with your local distributor for the proper CCD spacer for the camera and filter wheel that will be used to image.

Photographic Accessories

Dedicated accessories are available for attaching a camera to the E-180ED.

■ Wide T-Mount

When a SLR camera is attached, a wide T-mount is used as shown in the Fig.20. The following wide T-mounts are available from Takahashi. Canon EOS/Canon FD/Nikon/Minolta alfa/Pentax-K/Olympus-OM

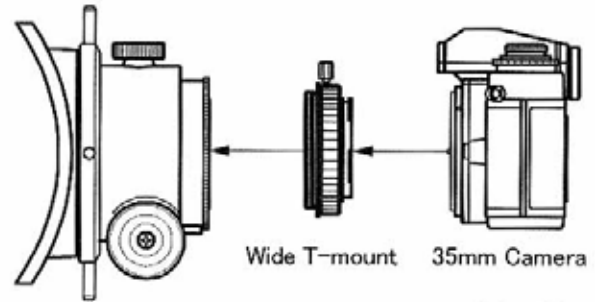

Fig.20

■ 75mm square filter box & aux ring

When a large format 6x7 is used, 75mm filter box and aux ring are required. Refer to the Fig. 21. A 6x7 film holder is available from Takahashi.

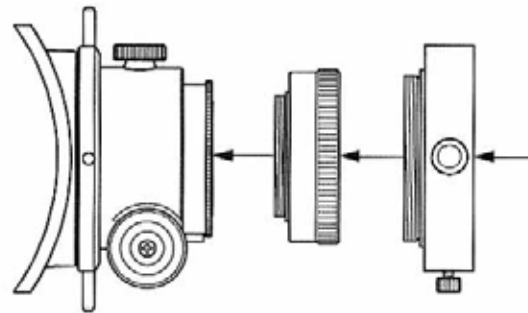

Fig.21

Optical Alignment

The E-180ED is collimated and locked before shipment. It is possible due to severe shock that the optics could be decollimated. Further, they will come, many years away, when the optics should be cleaned. Therefore it is a good idea to become familiar with the collimating procedure to keep the optics perfectly collimated to produce top notch images.

In the event that the instrument becomes decollimated, use the following procedure to precisely collimate the optics.

Precise collimation is necessary to achieve the optical potential of this fast system.

■ Collimating Tools

The following tools are required to collimate the E-180ED.

1. Visual adapter, coupling (S), ocular adapter, 2mm, 2.5mm, 3mm Allen wrenches and 8mm, 10mm and 17mm open end wrenches. These are supplied as standard accessories.

2. Collimating tube and eyepiece, standard for U.S. and optional for other markets.
3. Large screw driver available in a hardware or tool store.

■ Connection (1)

Tighten the camera angle adjuster lock ring by turning one of the four spokes clockwise.

Remove the corrector connecting the visual adapter to the draw tube.

Be sure to remove the corrector assembly, because the instrument cannot be collimated if it is not removed.

Visual Adapter/Collimating Tube/Coupling (S)/ Ocular Adapter (1 1/4")/ 1 1/4" Collimating Eyepiece

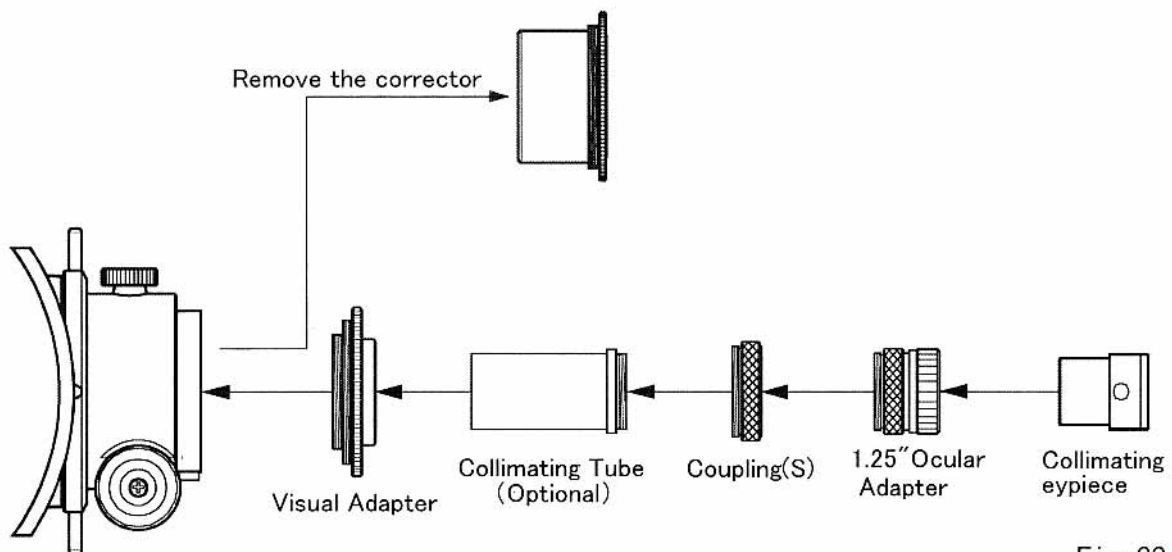

Fig. 22

■ Connection (2)

Using the collimating eyepiece and collimating tube will be a great help in collimating the E-180ED. The collimating tube has a provision for the insertion of a crosshair. Use nylon thread pulled together taught and four small pieces of tape to secure the crosshair. Then these strands can be glued for a permanent set up.

When collimation is necessary, a process that is done during the day in a bright lit room; the telescope can be pointed at a brightly lit white wall or at a translucent white sheet laid across a window. Place the tube with the focuser to the left as facing the light source. The figure illustrates the set up just described. (It is suggested that if possible you attach the E-180ED to the mount. This will make pointing and leveling the OTA and pointing it towards the light source simple.) If you lose your orientation to the movement of the secondary, place your finger over the opening of the tube to regain your orientation.

The directions of the field of view correspond to the numbers 1 through 4 on the illustration.

- Collimating mark on the primary
- Collimating mark on the secondary

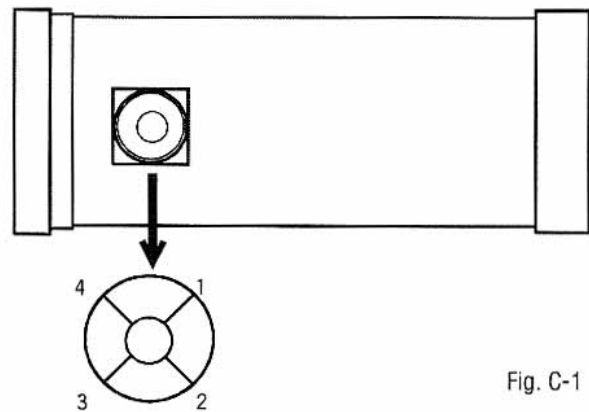
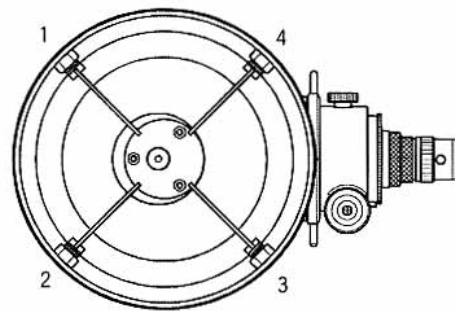

Fig. C-1

■ Adjusting the Secondary Mirror

The secondary can be adjusted by loosening the large nut at the center to turn it and the three small sets of screw to tilt it.

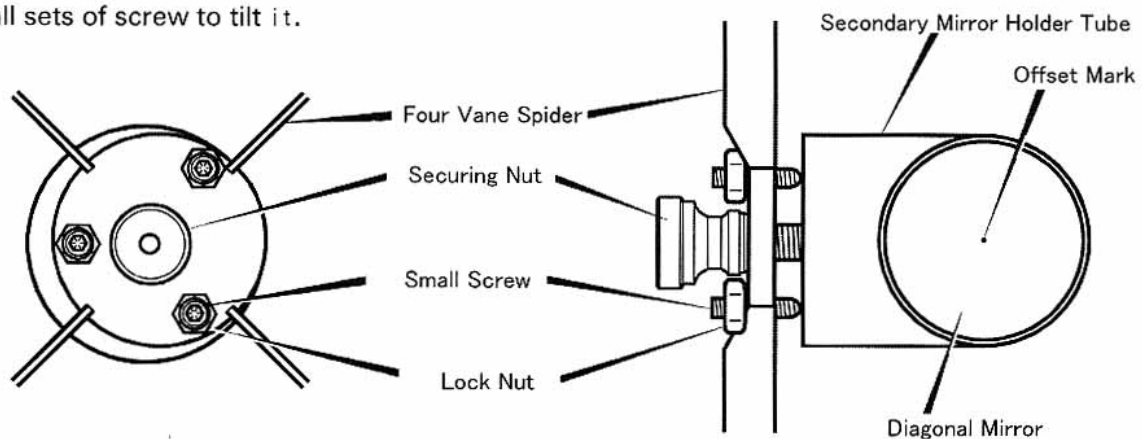

Fig. C-2

1. Turning the mirror

Loosen the large securing knurled nut that holds the secondary assembly to the spider slightly by turning it counter-clockwise. This will allow the secondary to be turned in either direction and then tightened by turning the nut clockwise. When the securing nut is loosened, loosen the nut very sparingly to allow the secondary to be turned, but not too loose.

2. Moving the secondary mirror

Loosening the large knurled knob some distance will allow the secondary to be moved up or down in a parallel fashion for better collimation.

3. Tilting the secondary mirror

There are three screws with locking nuts provided to allow the secondary mirror to be tilted for collimation. In order to tilt the secondary, it is necessary to loosen the lock nuts. Loosen each slightly to prevent the secondary from moving too much. Refer to the Fig. C-3

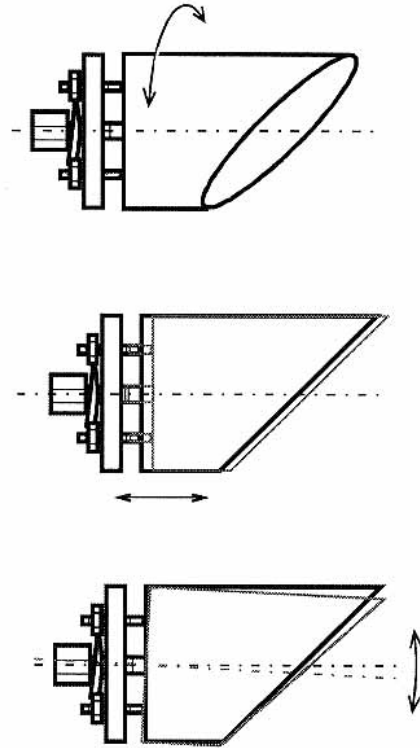
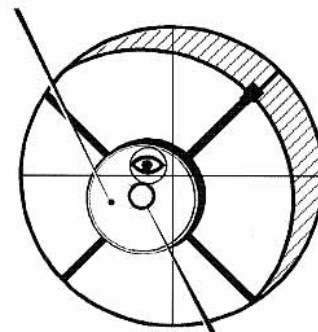

Fig. C-3

◆ Aligning the Secondary Mirror

- ① Turn the corsshair of the collimating eyepiece so that one set of lines is parallel to the ground which would make the second set of lines perpendicular. Make certain that the telescope is pointing at the white card or the window which a translucent curtain. In the event that the optical is rotated as shown in the Fig. C-5A.
- ② Loosen the large knurled nut holding the threaded rod of the secondary holder and turn the secondary as showin in the Fig. C-4.
- ③ Rotate the secondary until your eye reflected in the diagonal as it is centered in the crosshair. With the reflection of your eye in centered in the crosshair, slightly tighten the knurled nut. Refer to the Fig.C-5B.

Collimating mark on the secondary



Collimating mark on the primary

Fig. C-5A

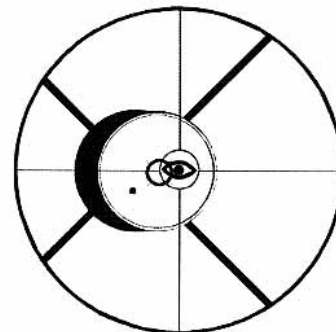
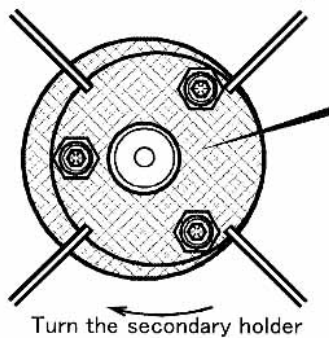

Fig. C-5B



Loosen and turn. Then, tighten it by hand the secondary.

Fig. C-4

Turn the secondary holder

- ④ Insert the collimating eyepiece and tilt the secondary mirror until the dot on the surface is over the center of the crosshairs. In the illustration Fig. C-7, the center of the collimating eyepiece matches the center of the crosshair, but the secondary dot is located low and to the left. The secondary must now be tilted toward the primary mirror mark (+) and the (+) must be moved upwards.

Slightly loosen the push screws A, B, C after backing off the lock nuts. Loosen the large knurled nut in the center and tighten the push screws A, B and C. Refer to the Figs. C-8 and C-9.

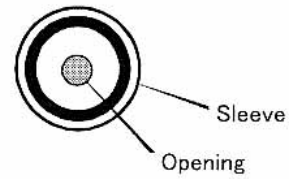

View of the collimating eyepiece

Fig. C-6

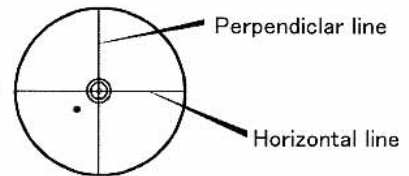

Fig. C-7

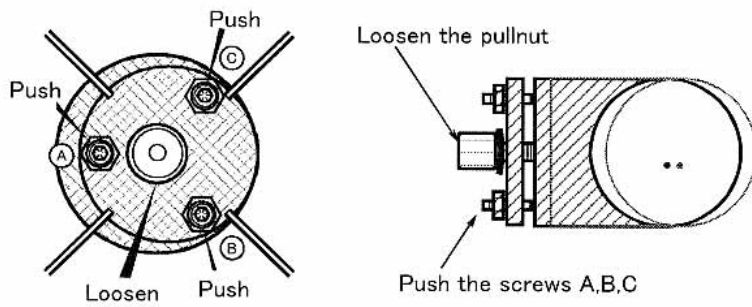

Fig. C-8

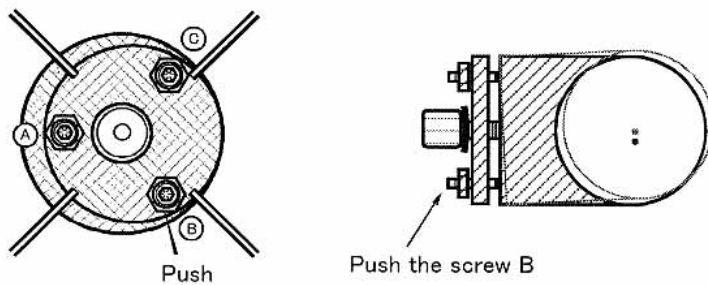
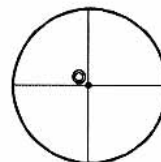

Fig. C-9

Now the center dot of the secondary has been shifted below the center of the crosshairs. It then becomes necessary to tilt the secondary using screws A, B and C to center the dot on the secondary with the center of the crosshairs.



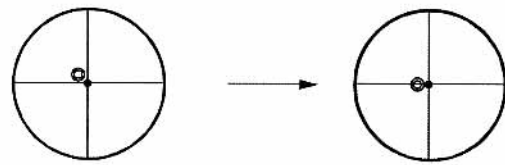
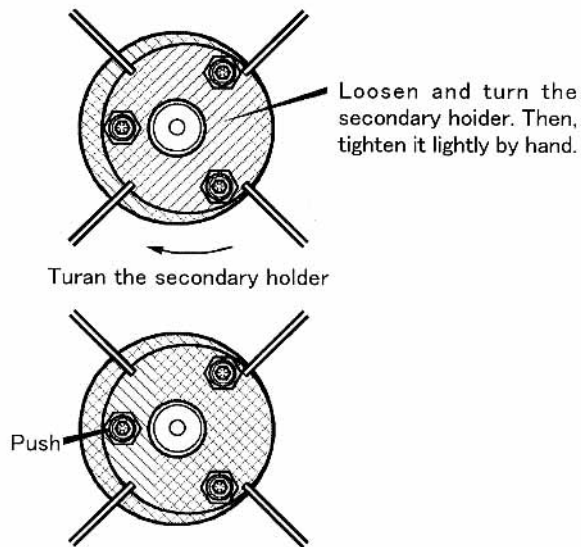

Fig. C-10

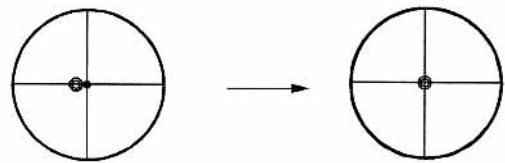
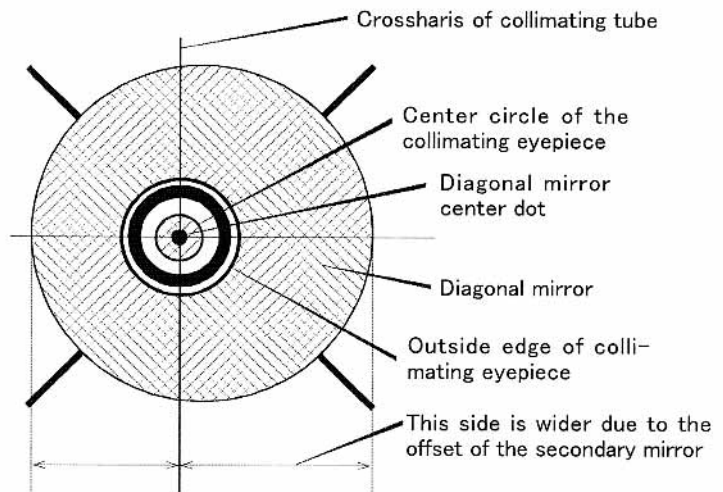

Fig. C-11

⑥ In this process the center of the reflection of the collimating eyepiece has been shifted off center as seen in the Fig. C-10. Then it becomes necessary to rotate and tilt the secondary mirror so that the center of the reflection of the collimating eyepiece is centered on the crosshairs. In the Fig. C-10 the secondary is rotated so that the reflection is on the crosshair and in the Fig. C-11 the secondary is tilted so that the center reflection of the collimating eyepiece is centered on the crosshairs by tightening push screw A.



【This figure illustrates the collimation of the correct secondary mirror.】
(Note: In this illustration the circle on the primary mirror has been left out.)

Fig. C-12

⑦ Now the center reflection of the collimating eyepiece is centered over the crosshairs as well as the center dot on the secondary mirror.

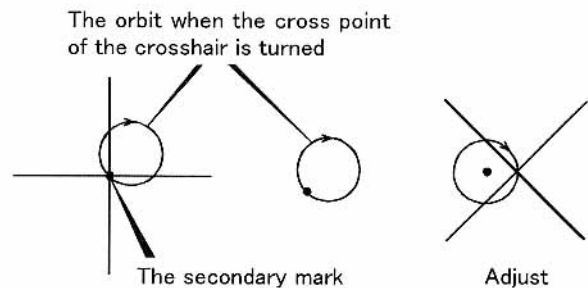
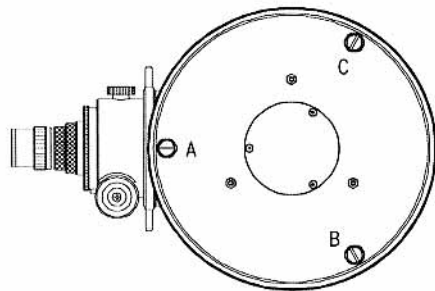

Fig. C-13

◆ Collimating the Primary

As you look through the collimating eyepiece you will notice that the circle on the primary mirror is not centered on the reflection of dot on the surface of the secondary and the collimating eyepiece.

It is now necessary to tilt the primary to center the circle on dot placed on the secondary and the collimating eyepiece pattern.



Primary mirror adjusting screw; A, B, C. Fig. C-14

You will use the 19mm open end wrench supplied and a large screw driver.

Look at the illustration of the rear of the mirror cell. You will note that the three collimating screw sets are labeled counter-clockwise A, B & C.

Please study the illustration of the cross section of the collimating screw sets. The illustration shows the pull screw which is the screw at the center with the large slotted knurled head, the lock nut and the push screw. The push screw is adjusted by loosening the lock nut and turning the push screw with the 19mm open end wrench. The center pull screw is also used to attach the mirror cell to the rear of the telescope and is adjusted with a large bladed screw driver.

Noting the location of the circle on the surface of the primary in the image of the collimating eyepiece, adjust the primary mirror.

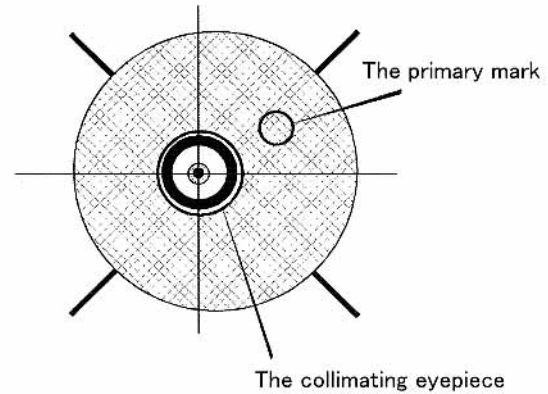
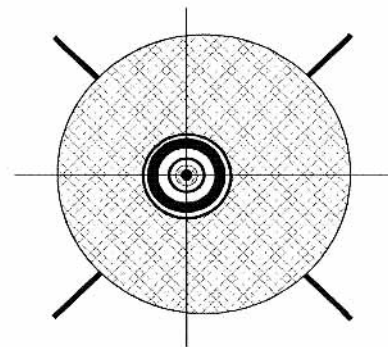
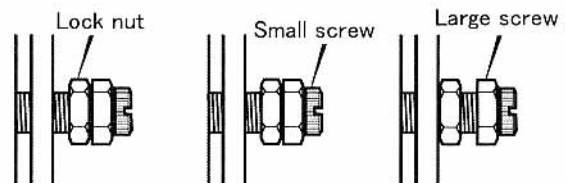
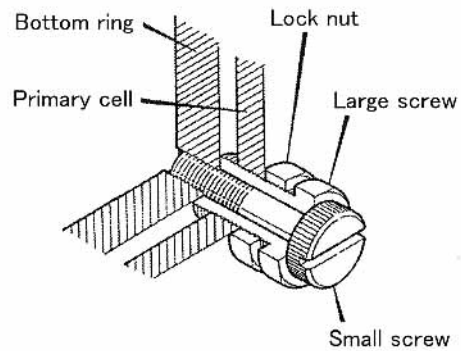

Fig. C-15



[When the collimation has been achieved]

Fig. C-16



◆ Adjusting the Primary Mirror

It is best to have the E-180ED on the mount pointing as close to straight up as possible to use gravity to make certain that the movement of the mirror will be permanent and it will ensure that the cell is seated properly.

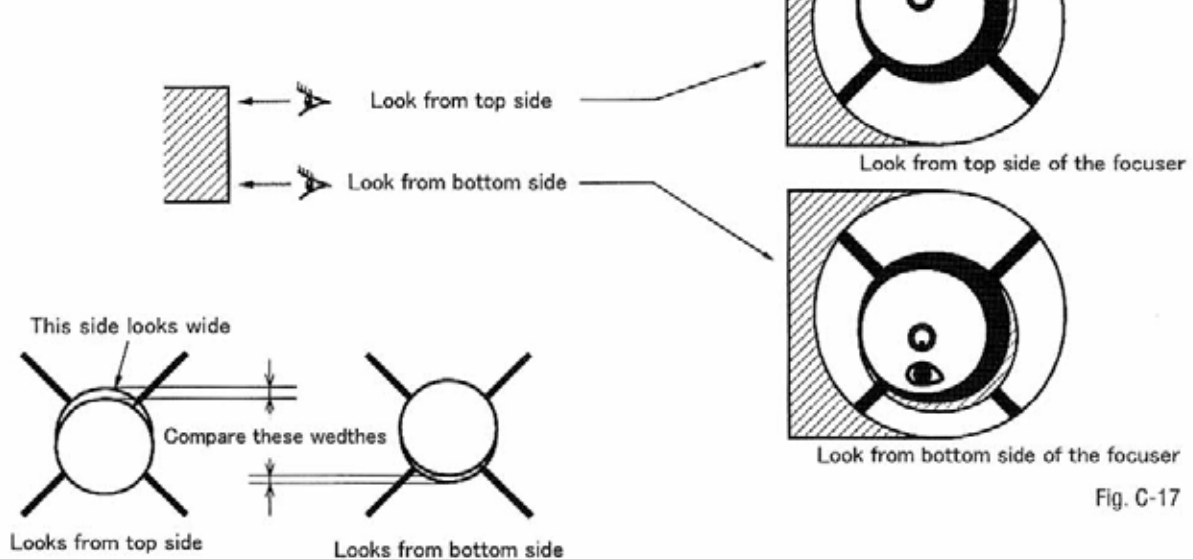

Fig. C-17

Fig. C-18

1. Loosen all the pull screws.
2. Then loosen all of the lock nuts.
3. Using the 19mm open end wrench tilt the primary so that the circle is moved to be concentric with the pattern on the diagonal reflection as seen through the collimating eyepiece.
4. Then tighten the pull screw and all of the locking nuts with the 19mm wrench. Check the image after this is done to make certain that the adjustment has been locked in place.

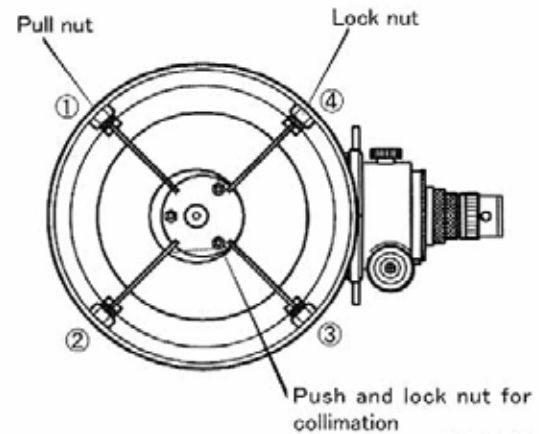

Fig. C-19

Now, turn the focuser with the Camera Angle Adjuster. As seen in the Fig.C-13 the crosshairs will orbit around the center dot on the secondary.

Therefore, further fine adjustments are required.

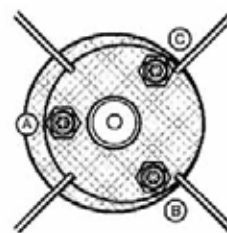

Fig. C-20

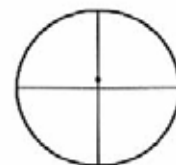

Fig. C-21

◆ Additional Collimation (Perfecting Collimation)

Loosen the lock ring located at the base of the focuser which will allow the focuser to be rotated (see page 7). Note that the crosshairs may move off the center pattern of the collimating eyepiece as the focuser is rotated. If so, further fine collimation is required. (Note: This fine collimation has already been performed by the factory.)

Please rotate the focuser 180° note the position of the crosshair in relation to the center of the collimating eyepiece as the focuser is turned.

The crosshair will move right and left defining a center in between. Then, rotate the focuser 90° and this will move the crosshair up and then move the focuser 180° which will define the lowermost position. Now bearing in mind the furthest left, right, upper most and furthest down position will define a center. This will define the new center for perfect collimation.

Use the above procedure to move the crosshair so that when the focuser is rotated, the crosshair rotates evenly around the center of the field as viewed through the collimating eyepiece. (Remember that this procedure has been already been performed at the factory.)

◆ Diffraction Ring

Since the diagonal mirror of the E-180ED is offset to produce a fully illuminated image circle, when the visual image is defocused the diffraction ring will appear eccentric. This is perfectly normal. This does not an indication of decollimation.

【NOTE】

Before attempting any adjustment for the primary, secondary, and spider, please ask your local distributor. Doing any adjustment yourself without notice will make warranty void.

Care & Maintenance

■ Primary and Diagonal Mirror

When they get dew on their surface during observation or when they get moisture on the mirror after the scope is brought into warm room from cold outside, dry it immediately. Dew and moisture may cause the mirrors and fixtures get musty and dirty. When the diagonal or the primary mirror gets dust on it, take it out with the cell together and blow out the dust by a hand-power blower. When mold or rust covers all the mirror, cleaning or recoating may be required. In such case, ask your dealer what to do.

A slight pressure on the mirror may cause the stellar images distorted. A great care must be taken when the cell is set in place after repairing service. Do not set the screw too tight. Sharp edge of the diagonal can be chipped by a shock on it. Be careful in handling.

■ Corrector Lens

Never take out the corrector lens from its cell. It is very difficult for amateur to align the lens to keep its right performance and doing so will make warranty void. If the lens surface gets dust, take out the assembly from the drawtube and blow out the dust by a handpower blower. Should it get dirt or fingerprints on the lens, wipe it gently with a swab moistened with lens cleaner, turning it from the center toward the edge.

■ Tube

Dust on the main tube can be wiped off with a duster and stained dirt on the tube can be cleaned with a car wax.

■ Visual Adapter Assembly

The focuser may come to be loosened after a long period of use. It can be fixed by the adjusting screws provided on the focuser as show in the Fig.23. Be careful not to tighten the focuser too much.

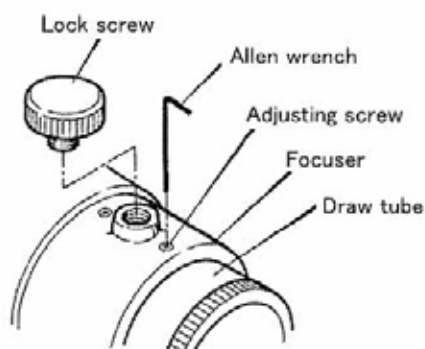
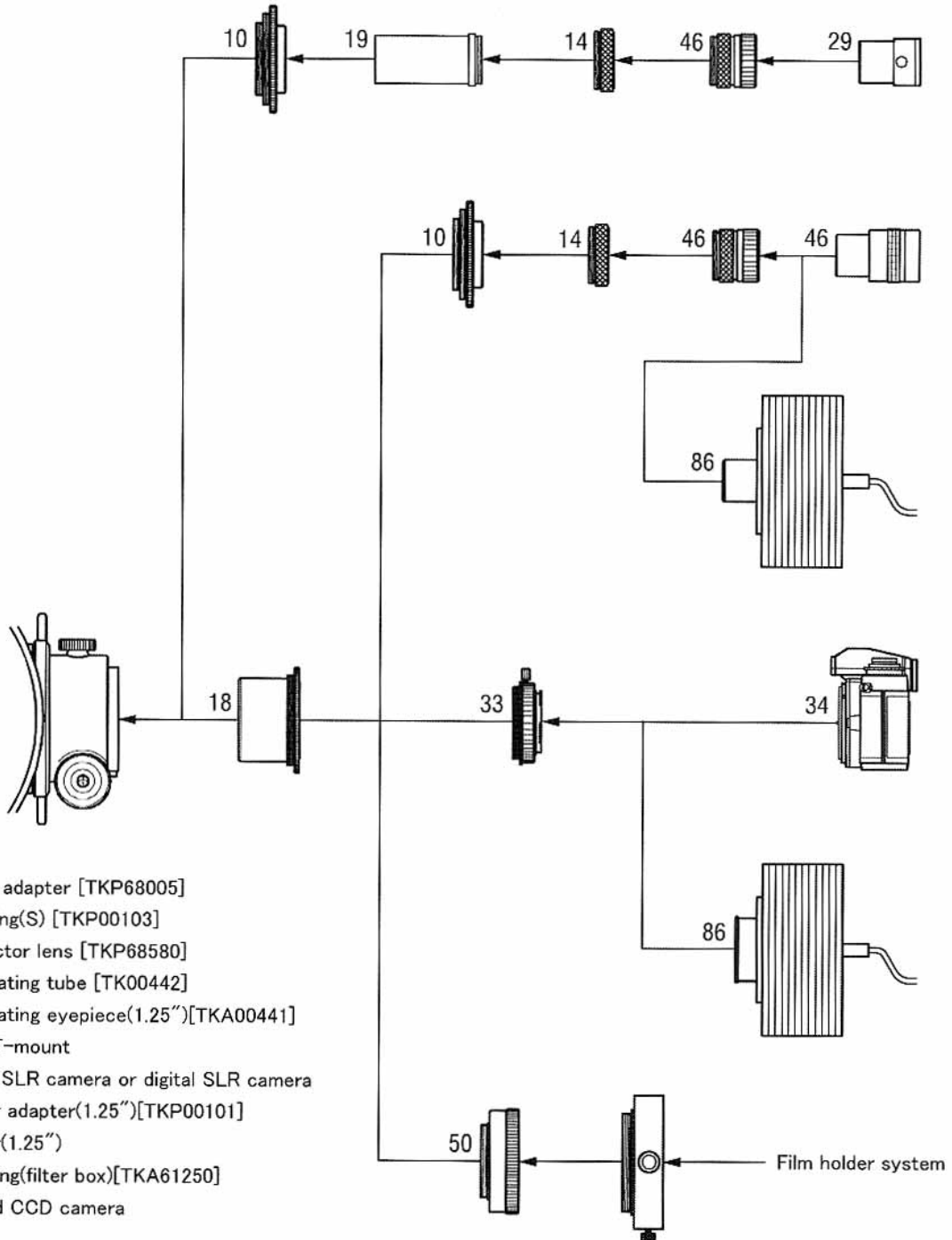

Fig. 23

System Chart



- 10. Visual adapter [TKP68005]
- 13. Coupling(S) [TKP00103]
- 18. Corrector lens [TKP68580]
- 19. Collimating tube [TK00442]
- 29. Collimating eyepiece(1.25") [TKA00441]
- 33. Wide T-mount
- 34. 35mm SLR camera or digital SLR camera
- 46. Ocular adapter(1.25") [TKP00101]
- 47. Ocular(1.25")
- 50. Aux. ring(filter box) [TKA61250]
- 86. Cooled CCD camera

- * Parts Nos. 10, 14, 18, and 46 are standard with the tube assembly.
- * Some 35mm camera may not be connected with the wide T-mount.
- * Some CCD cameras may not be connected with the ocular adapter.